

# ME 308

## MACHINE ELEMENTS II

### CHAPTER 5

### GEARS\_part2

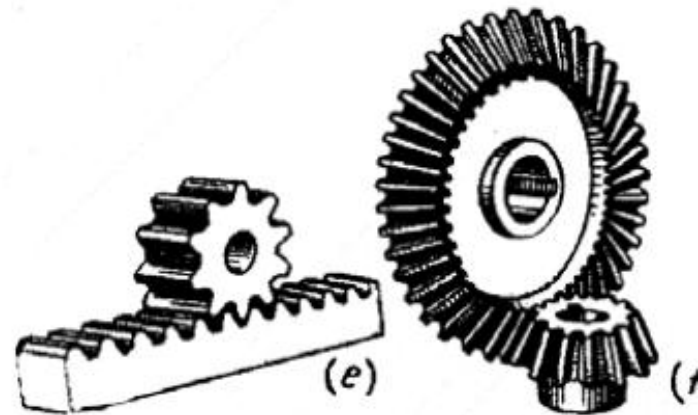
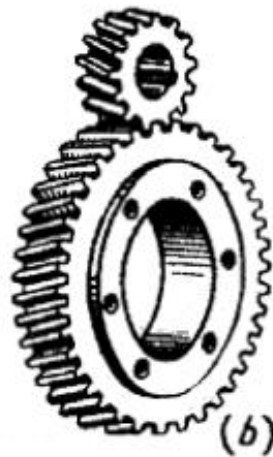

# 5.5 FUNDAMENTALS

The center distance of two mating gears is the sum of the pitch radii ( $CD=r_1+r_2$ ). Pinion and gear centers are located at  $O_1$  and  $O_2$ . Then the pitch circles of radii  $r_1$  and  $r_2$  are constructed. These two circles are tangent at pitch point  $P$ .

Fig. 5.10 Circles of a gear layout.

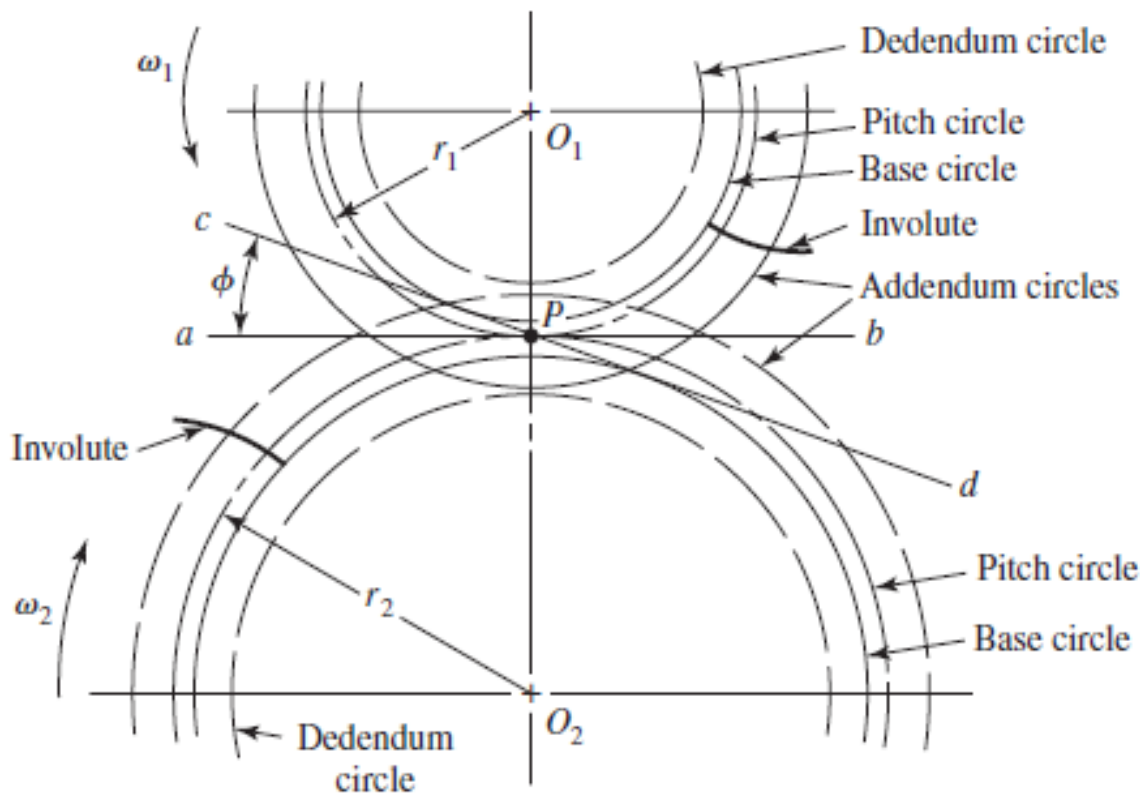

Next draw line  $ab$ , the common tangent, through the pitch point.

We now designate gear 1 as the driver, and since it is rotating counterclockwise, we draw a line  $cd$  through point  $P$  at an angle  $\phi$  to the common tangent  $ab$ .

Line  $cd$  is called the pressure line and the angle  $\phi$  is called pressure angle.

The line  $cd$  has three names, all of which are in general use. It is called the pressure line, the generating line, and the line of action.

It represents the direction in which the resultant force acts between the gears.

The angle  $\phi$  is called the pressure angle, and it usually has values of  $20^\circ$  or  $25^\circ$ , though  $14^{1/2^\circ}$  is also used.

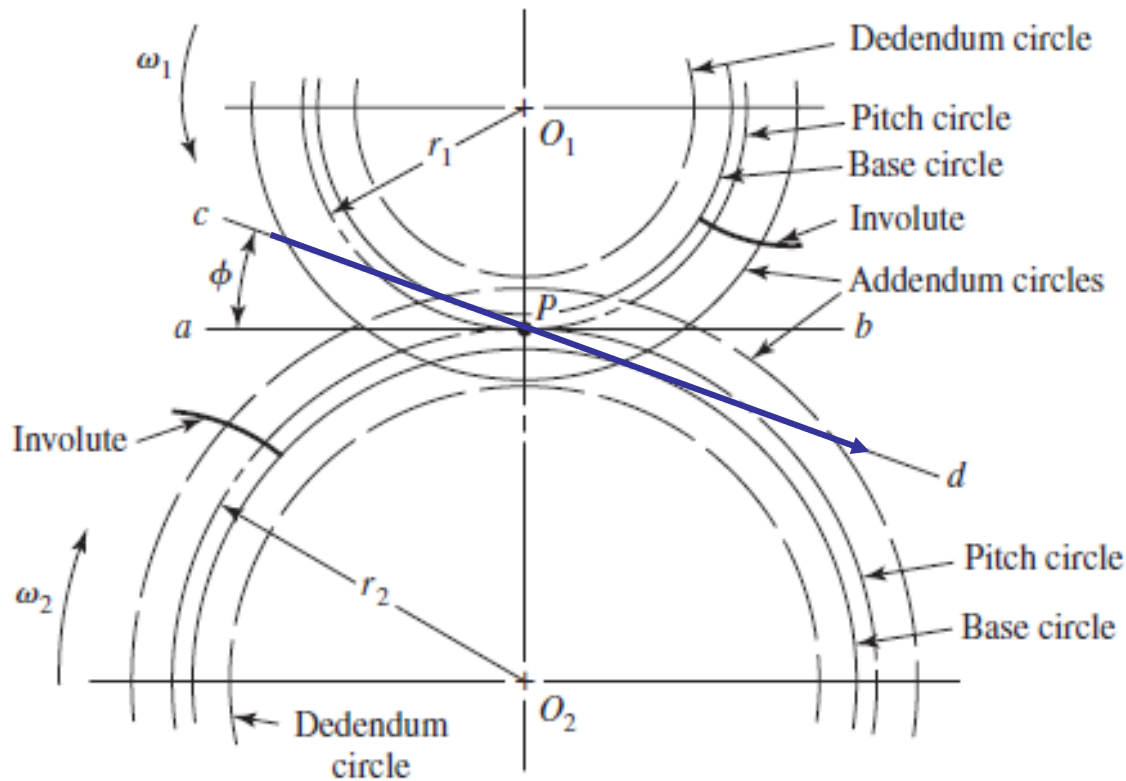

Pressure angles of both gears should be the same for a proper mating

$$\phi_1 = \phi_2$$

Fig. 5.10 Circles of a gear layout.

on each gear you can draw a circle tangent to the pressure line. These circles are called base circles.

Since they are tangent to the pressure line, the pressure angle determines their size. As shown in Fig, the radius of the base circle is

$$r_b = r \cos \phi$$

where  $r$  is the pitch radius.

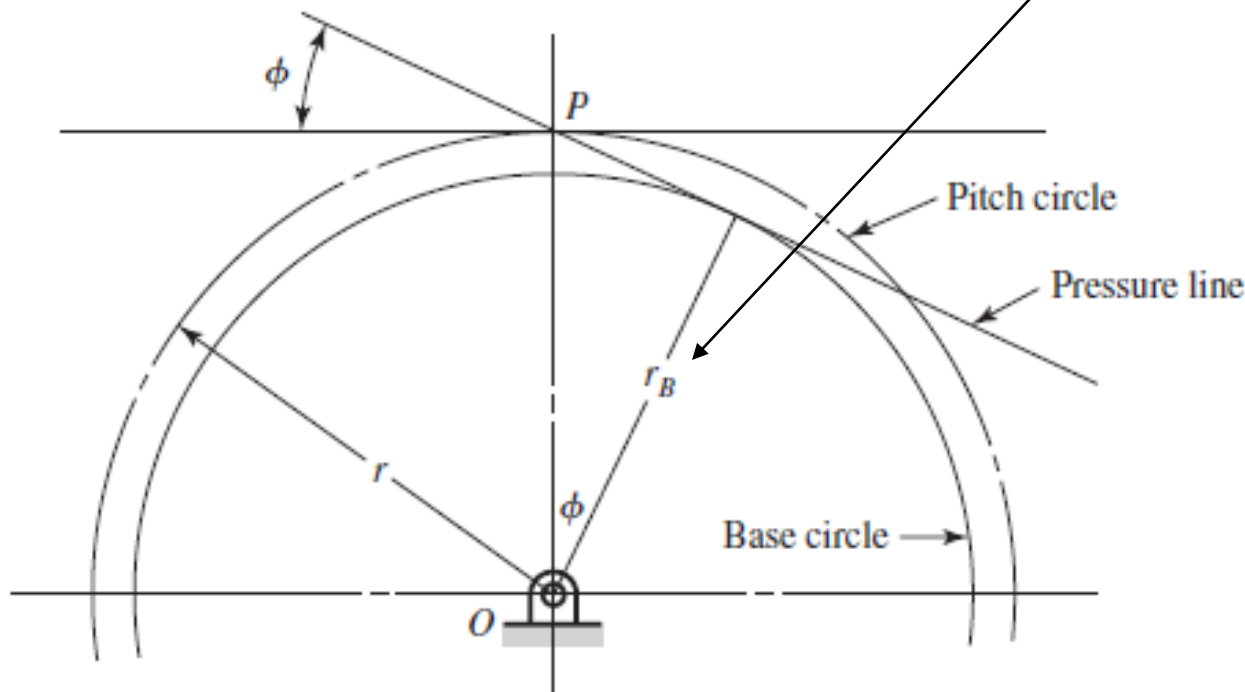

Fig. 5.11 Base circle radius can be related to the pressure angle  $\Phi$  and the pitch circle radius by  $r_b = r \cos \Phi$ .

The addendum and dedendum distances for standard interchangeable teeth are usually :

$a=1 \cdot \text{module}$  and  $b=1.25 \cdot \text{module}$  in SI units and ,

$a=1/P$  and  $b=1.25/P$ , in American units.

Using these distances, draw the addendum and dedendum circles on the pinion and on the gear as shown in Fig. 5.10.

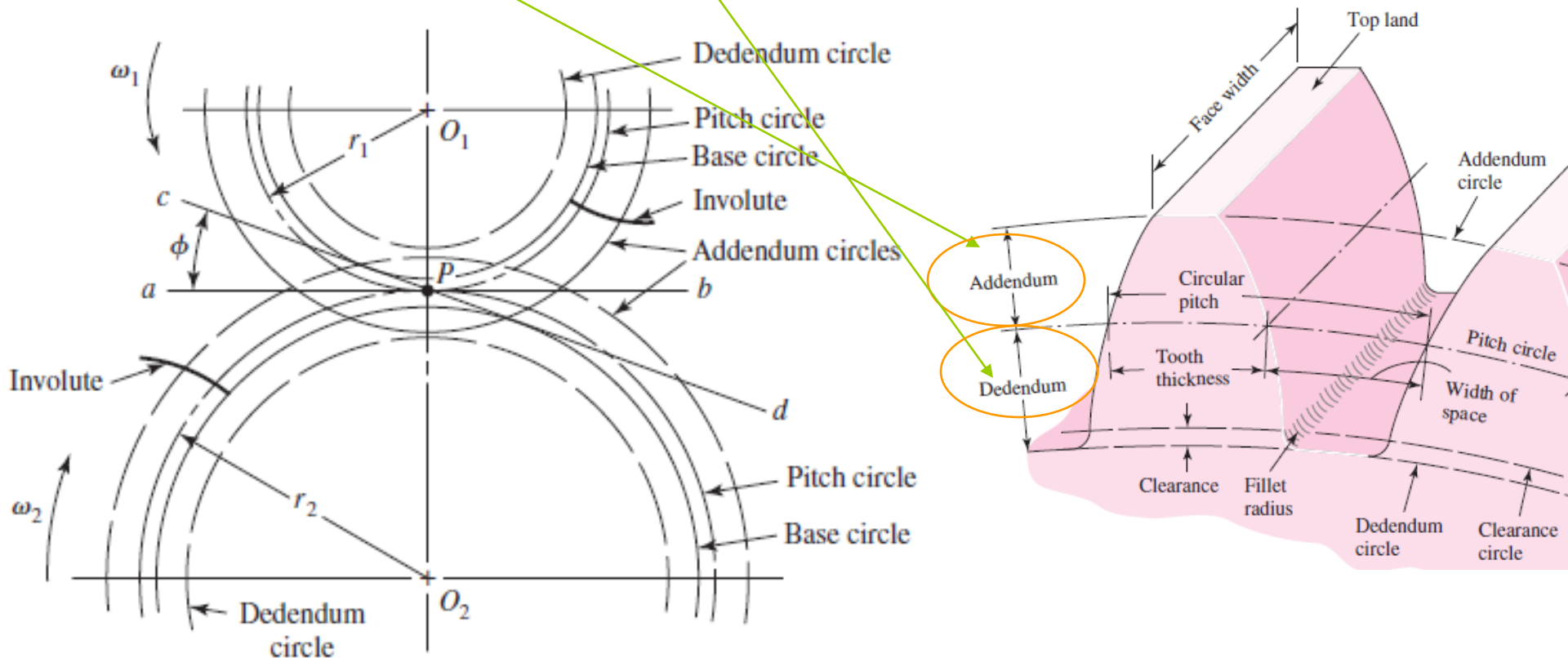
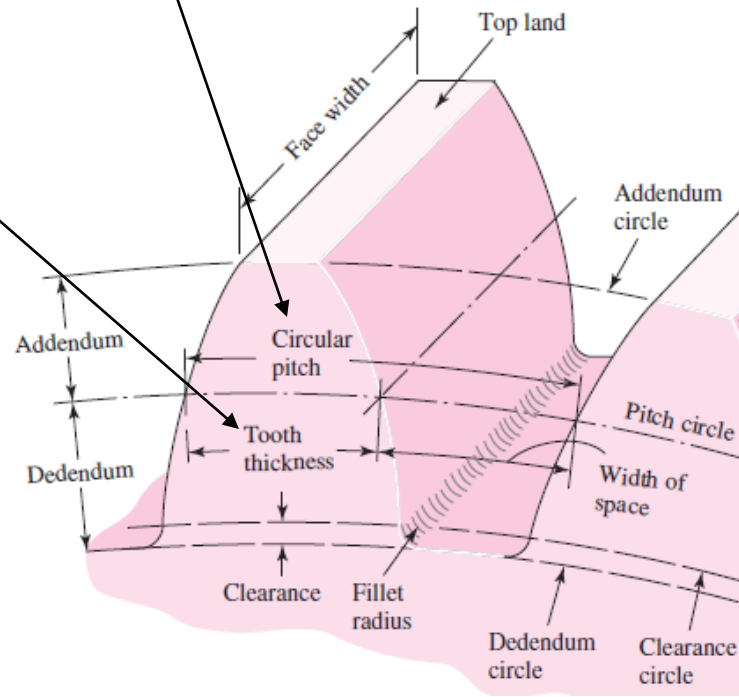

Fig. 5.10 Circles of a gear layout.

Circular pitch and tooth thickness of gears are measured on pitch circles and found from relations:

$$p_c = \frac{\pi d}{N} = \pi \left( \frac{d}{N} \right) = \pi m; \quad \text{in mm.}$$

$$t = \frac{p_c}{2} = \frac{\pi m}{2}$$



The portion of the tooth between the clearance circle and the dedendum circle includes the fillet where bending stress occur.

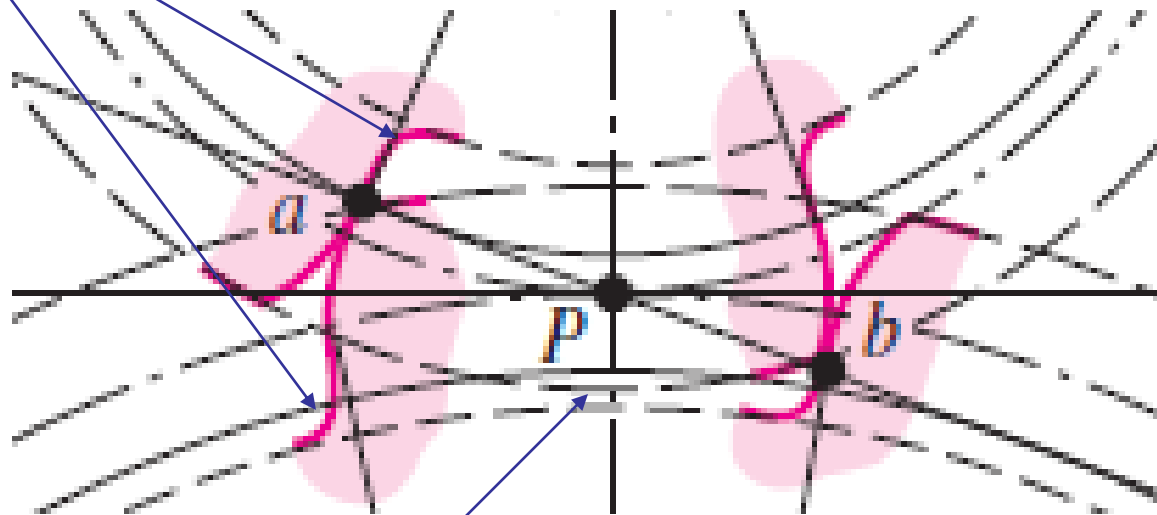

$$c = b - a = (1.25 - 1.00) * m = 0.25 * m$$

We may imagine a *rack* as a spur gear having an infinitely large pitch diameter.

Therefore, the rack has an infinite number of teeth and a base circle which is an infinite distance from the pitch point.

The sides of involute teeth on a rack are straight lines making an angle to the line of centers equal to the pressure angle. Figure 5.14 shows an involute rack in mesh with a pinion.

Corresponding sides on involute teeth are parallel curves; the *base pitch* is the constant and fundamental distance between them along a common normal as shown in Fig. 5.14.

The base pitch is related to the circular pitch by the equation

$$p_b = p_c \cos \phi$$

where  $p_b$  is the *base pitch*.

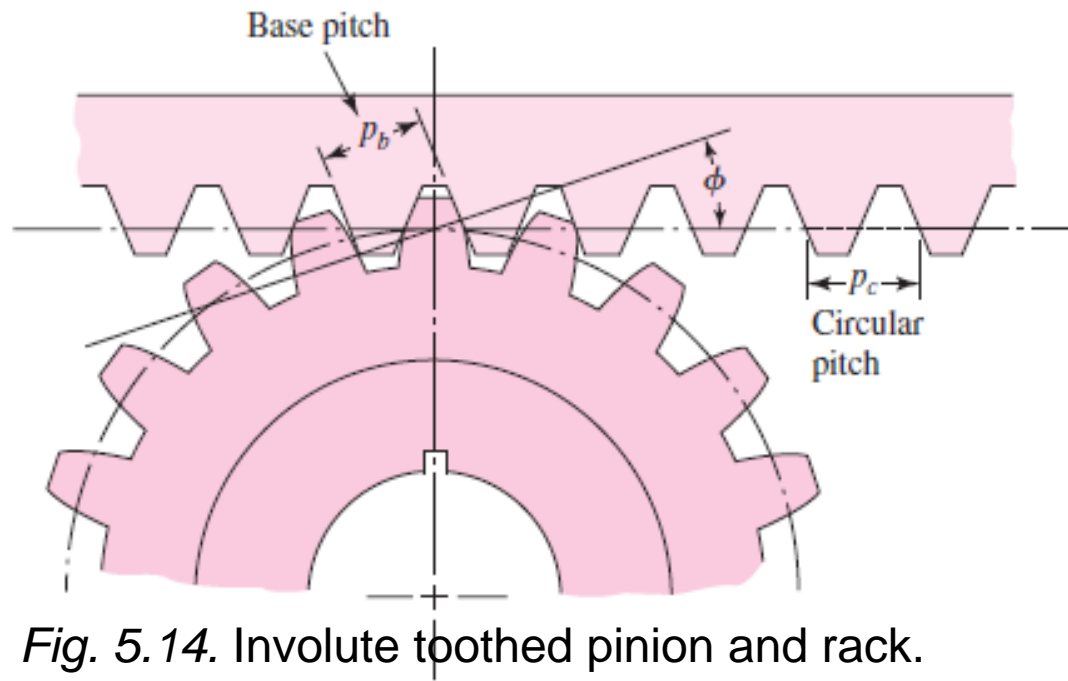
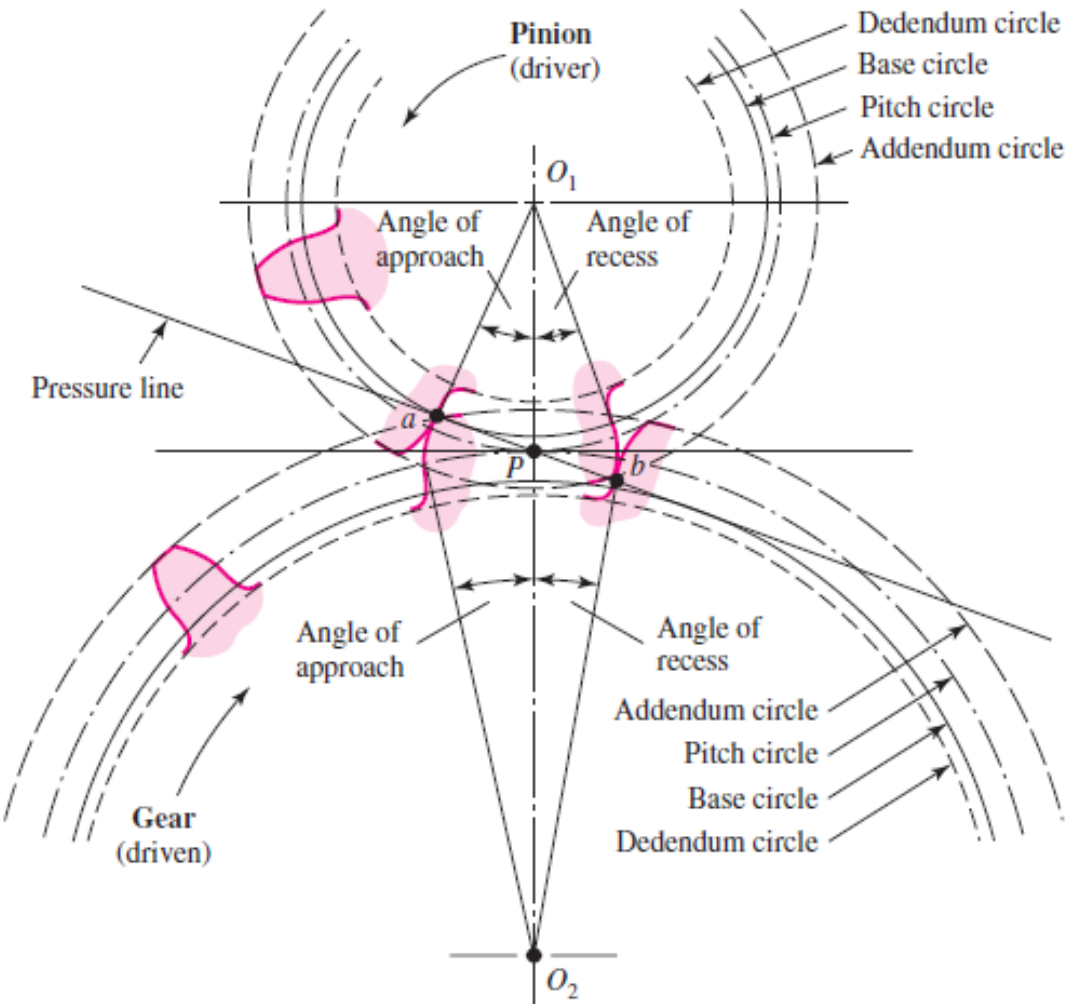

Fig. 5.14. Involute toothed pinion and rack.

Another interesting observation concerns the fact that the operating diameters of the pitch circles of a pair of meshing gears need not be the same as the respective design pitch diameters of the gears, though this is the way they have been constructed in Fig. 5.13.



If we increase the center distance, we create two new operating pitch circles having larger diameters because they must be tangent to each other at the pitch point.

Thus the pitch circles of gears really do not come into existence until a pair of gears are brought into mesh.

Changing the center distance has no effect on the base circles, because these were used to generate the tooth profiles. Thus the base circle is basic to a gear.

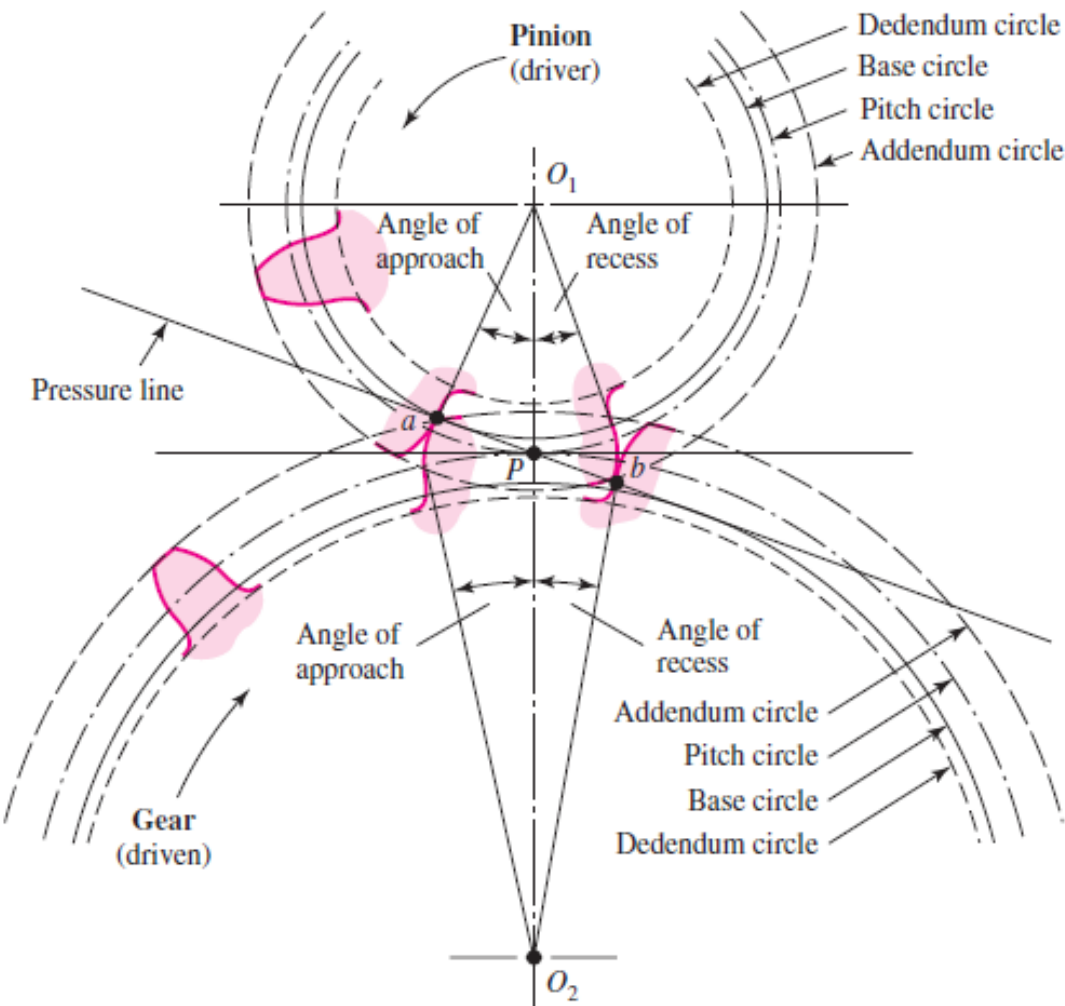

Increasing the center distance increases the pressure angle and decreases the length of the line of action,

but the teeth are still conjugate, the requirement for uniform motion transmission is still satisfied, and the angular-velocity ratio has not changed.

The reason for this is because involute form is insensitive to center distance variation

Involute profile has the advantages of

- 1) Easy production of gears with standardized cutters.
- 2) Insensitivity to (gear ) center distance change, thus keeping the velocity ratio constant always.
- 3) Ensuring a constant velocity ratio from start of teeth engagement to the end of engagement.

Regarding manufacture of gears, gear teeth on gears are formed

- a) Either by forming methods of
  - casting (sand,die,centrifuge)
  - powder metallurgy
  - forging
  - cold forming or cold rolling etc
  
- b) Or by metal removal methods of
  - milling (form cutters)
  - shaping(pinion or rock cutters)
  - hobbing (worm type rack cutters most widely used one)

Quality gears to be used in aerospace & military vehicles or similar accurate applications are later finished by

- Shaving
- burnishing
- grinding or
- lapping.

<u>AGMA quality no(old)</u>	<u>DIN quality no</u>	<u>AGMA quality no (new)</u>
14 (highest quality)	1 (highest)	1 (highest)
13	2	2
12	3	3
.	.	
.		
.	9	9
1 (lowest quality)	10 (lowest)	10 (lowest)

For a pair of meshing gears (whether pinion & gear or pinion & rack does not matter):

- 1) The pressure angles of both gears have to be the same. Standart pressure angles are:
  - 20.0 degrees (most widely used)
  - 25.0 degrees (sometimes) and
  - 14.5 degrees (obselete)

press angle of pinion= press angle of gear

$$\Phi_p = \Phi_g$$

- 2) The module , m , has to be the same for both gears too.  
module of pinion=module of gear

$$m_p = m_g$$

<u>m</u> (mm)	<u>P</u> (teeth/in, <u>coarse</u> )	<u>P</u> (teeth/in, <u>fine</u> )
0.4	2	20 1/inc
0.5	2.25	24
0.8	2.50	32
1.0	3.0	40
1.25	4.0	48
1.50	6.0	64
2.0	8.0	.
3.0	10.0	.
4.0	12.0	.
5.0	16.0	200
6.0		
8.0		
10.0		
12.00		
16.0		

3) The addendum & dedendum relations should hold for a clearance between the tips & roots of the mating gears teeth

<u>a</u>	<u>b</u>	<u>b-a (clearance)</u>
1.0 m (in SI units)	1.25m	0.25 m
1.0/P (in American units)	1.25/P	0.25/P

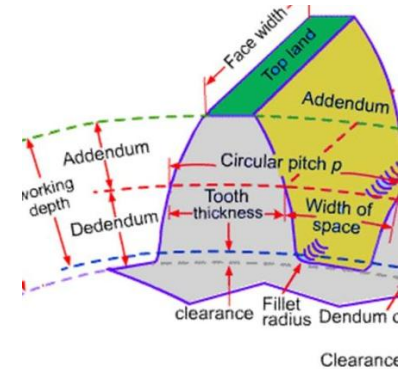

4) The top land ( tip of the teeth) should not point to zero thickness due to likely high loading & tooth breakage during meshing.

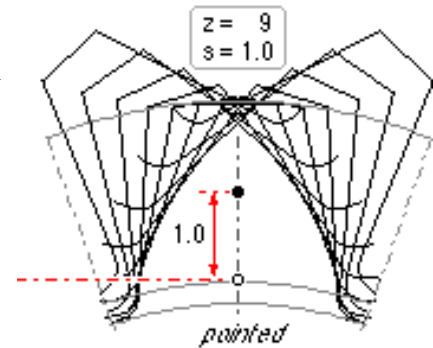

5) For a pair of involute gears (with same  $m$  &  $\Phi$ ) they mesh on a center distance of

$$CD = r_p + r_g = \frac{dp}{2} + \frac{dg}{2} = \frac{1}{2} (m * Tp + m * Tg)$$

$$CD = \frac{m}{2} (Tp + Tg)$$

Center line  
of gear  
centers

End of tooth  
contact (D)

Tip (addendum)  
circles

Base  
circles

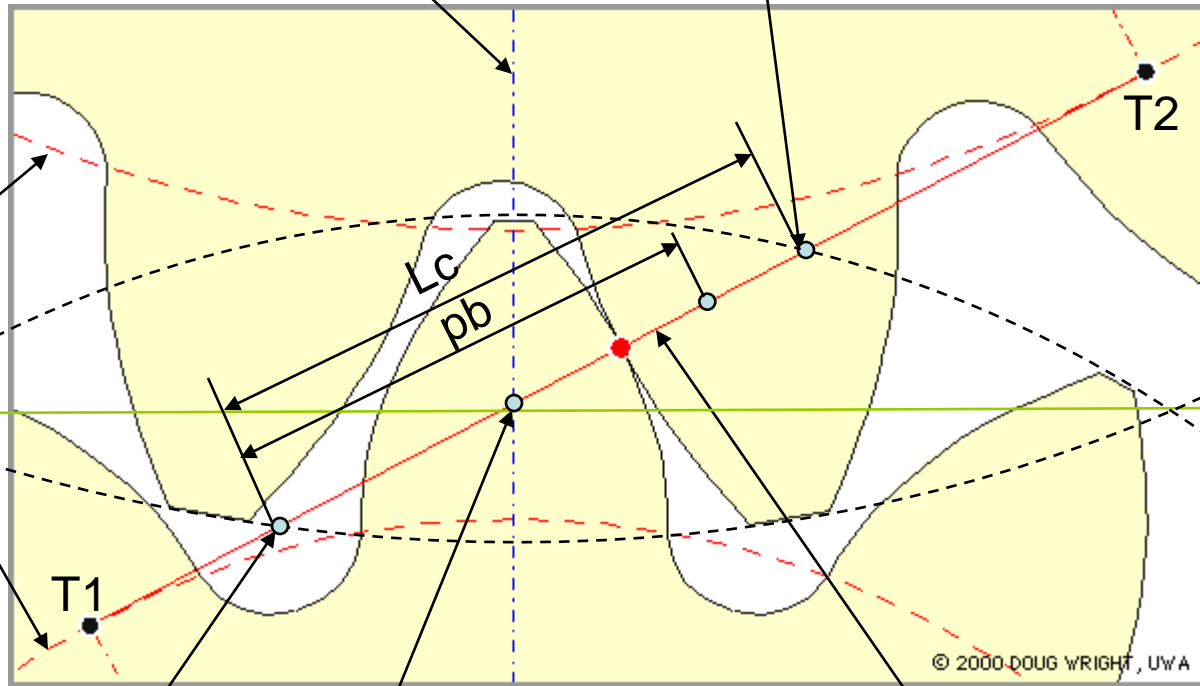

© 2000 DOUG WRIGHT, UWA

Start of tooth  
contact (A)

Pitch point (P)

Pressure line, Line of action,  
Generating line (tangent to base  
circles at two ends)

Point T1 is the tangent point of the pressure line with the base circle of pinion &  
 Point T2 is the tangent point of the pressure line with the base circle of gear.

Point A is the position where the teeth of the gear & pinion first come into contact and goes through point P (pitch point) along the pressure line and leaves the contact at point D.

Point A is the intersection of the pressure line (with angle  $\phi$ ) with the addendum circle of the driven gear.

Point D is the intersection of the pressure line with the addendum circle of the pinion (driving gear).

The distance  $L_c$  between points A & D along the pressure line is the length of the contact (through which the two meshing teeth stay in contact & carry load & transmit torque between shafts)

The relation of the  $L_c$  &  $p_b$  gives the measure of the uniformity or continuity of the motion transfer.

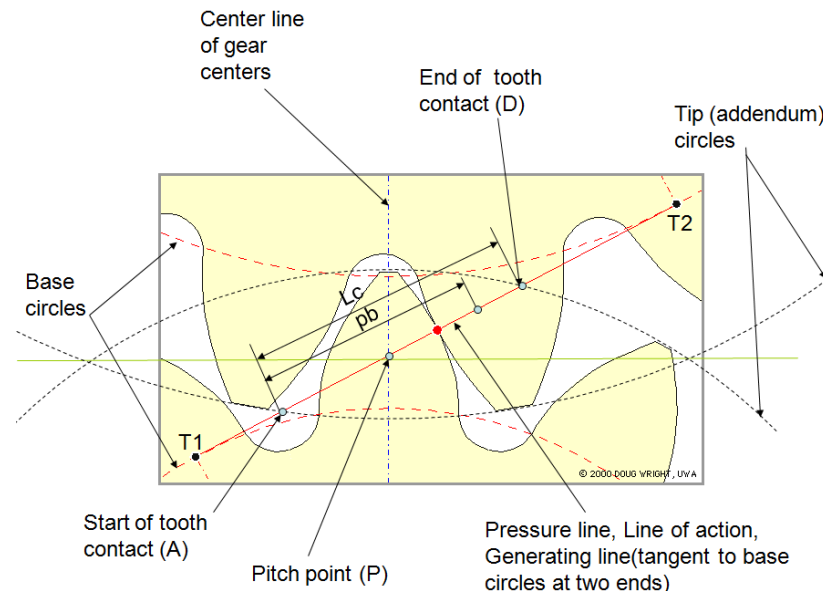

The contact ratio “CR” is defined as the average number of teeth in contact at any instant of mesh.

- Contact ratio has to be larger than unity for a continuous motion transfer.
- CR has to be larger than 1.2 to accommodate for any manufacturing & mounting errors.
- CR has to be between 1.6-2.0 for a stronger gear mesh.

$$CR = \frac{L_c}{P_b} = \frac{(\sqrt{r_{ap}^2 - r_{bp}^2} + \sqrt{r_{ag}^2 - r_{bg}^2}) - (\sqrt{r_p^2 - r_{bp}^2} + \sqrt{r_g^2 - r_{bg}^2})}{p_c * \cos\Phi}$$

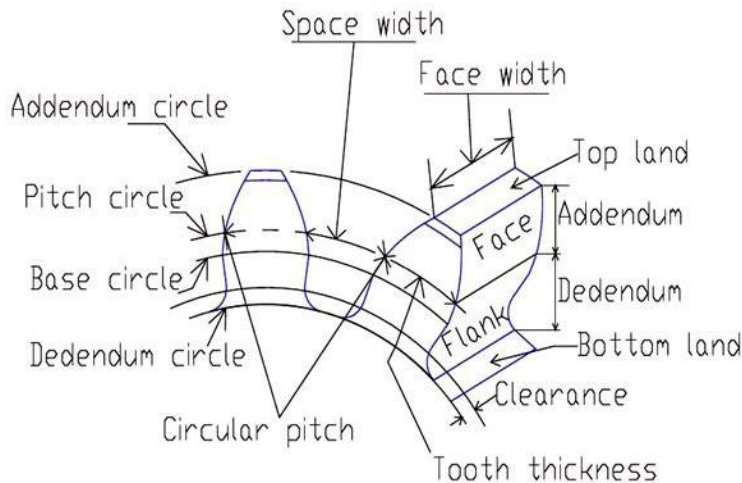

When a pair of gear with theoretical center distance equal to  $r_p + r_g$  is mounted at a new extended center distance

- the operating pressure angle,
- operating pitch circles &
- the contact ratio

will all change.

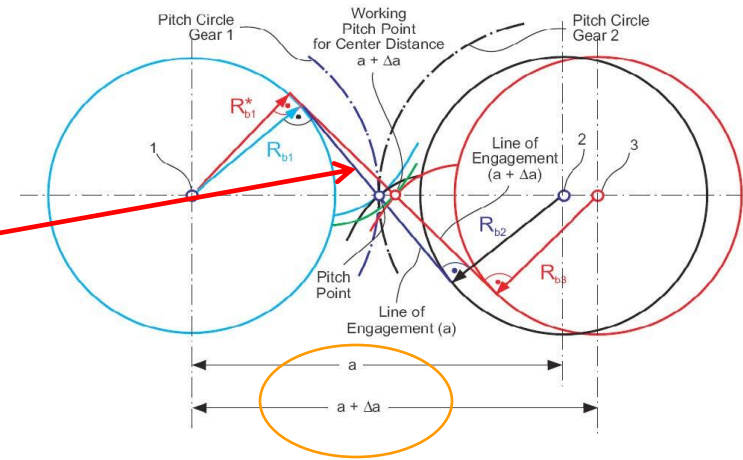

$$CR_{new} = \frac{L_{new}}{P_b} : L_{new} = \left[ \sqrt{r_{ap}^2 - r_{bp}^2} + \sqrt{r_{ag}^2 - r_{bg}^2} \right] - \left[ \sqrt{r_{p_{new}}^2 - r_{bp}^2} + \sqrt{r_{g_{new}}^2 - r_{bg}^2} \right]$$

But velocity ratio will not change.  $\left| \frac{\omega_1}{\omega_2} \right| = \frac{r_2}{r_1}$

Interference between tip of one gear & the root of the other gear of a pair occurs when a small pinion drives a large gear (at worst a rack with infinite dia.)

In such a case tip of the teeth digs into the root of other gear teeth & this happens especially below the base circle of the gear where the tooth profile is no more involute.

And sometimes extra material is removed from the root of the teeth thus weakening the teeth. To prevent such a case the minimum pinion tooth number is limited to

$$N_{\min} = \frac{2}{\sin^2 \phi}$$

thus for $\Phi$	: 14.5	20	25	degrees
$N_{\min}$	: 32	18	12	theoretically
$N_{\min}$	:	14		practically

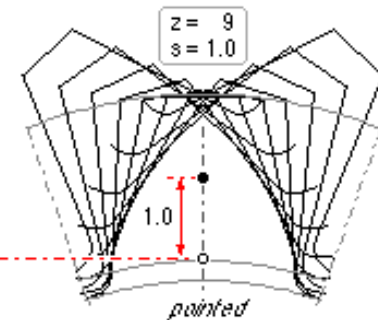
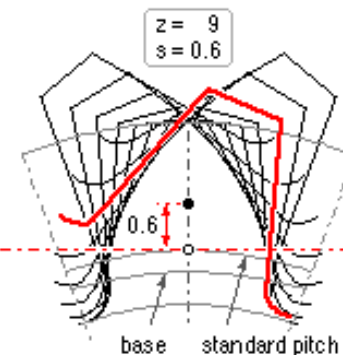
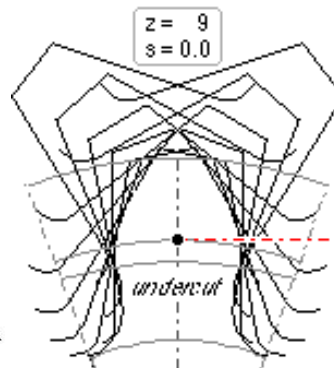
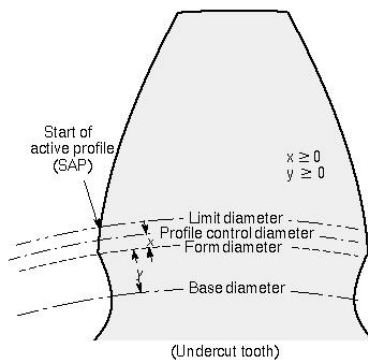
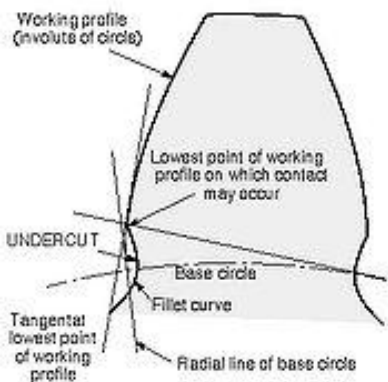

## Here is an example:

For a gear pair of 19tooth pinion meshing with a 37tooth gear of 6 diametral pitch and 20degrees pressure angle;

Determine:

- gear ratio, circular pitch, base pitch, pitch diameters, pitch radii, theoretical center distance, addendum, dedendum, whole depth, clearance, outside diameters, root diameters, and contact ratio.
- If the center distance is increased by 2% what will be the new pressure angle, new pitch radii and new contact ratio

Given:

$T_p=19$

$T_g=37$

$P=6\text{teeth/inch}$

$\Phi=20\text{degrees}$

Solution:

a) Gear ratio= $T_g/T_p=37/19=1.947$

Circular pitch,  $p_c=\pi*m=3.14*?$ ,  $m=25.4/P=25.4/6=4.233\text{mm}$   
 $p_c=13.300\text{mm}$

Base pitch,  $p_b=p_c*\text{Cos } \Phi=13.3*\text{Cos}20=12.497\text{mm}$

Pitch dia's  $d_p=m*T_p=4.233*19=80.427\text{mm}$

$d_g=m*T_g=4.233*37=156.621\text{mm}$

Pitch radii  $r_p=d_p/2=40.213\text{mm}$

$r_g=d_g/2=78.310\text{mm}$

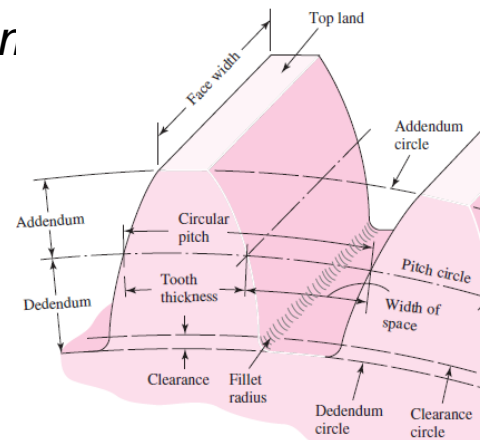

Nominal-theoretical center distance,  $CD=rp+rg=118.523\text{mm}$

Addendum,  $a=1.0*m=1*4.233= 4.233\text{mm}$

dedendum,  $b=1.25*m=1.25*4.233= 5.291\text{mm}$

Whole depth,  $h=a+b= 9.524\text{mm}$

Radial clearance,  $c=b-a= 1.058\text{mm}$

Outside diameter,  $dap=dp+2*a=(rp+a)*2= 88.892\text{mm}$

$dag=dg+2*a=(rg+a)*2= 165.086\text{mm}$

Root diameters  $drp= dp-2*b=(rp-b)*2=69.844$

$drg=dg-2*b=(rg-b)*2=146.038\text{mm}$

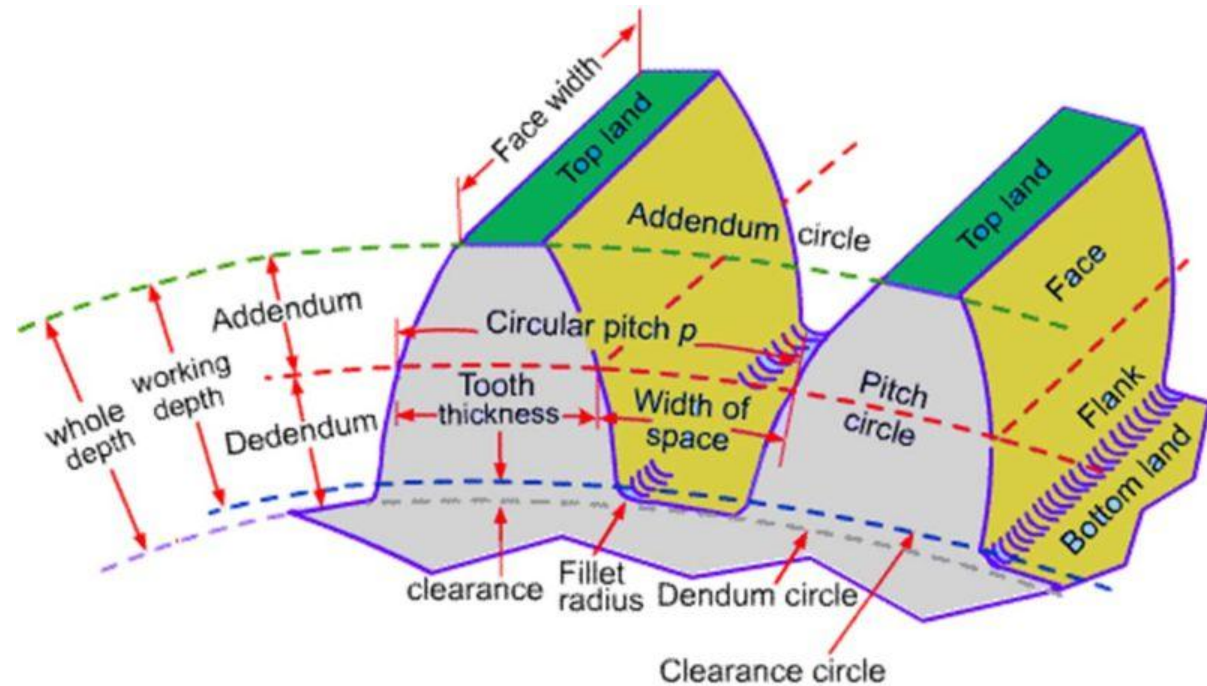

# Contact ratio

$$cr = \frac{L}{P_b}$$

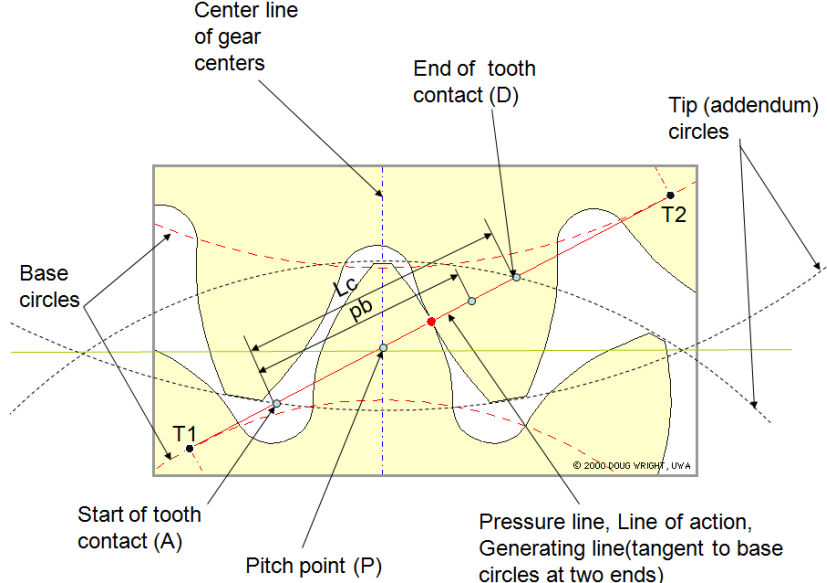

$$L = \left( \sqrt{r_{ap}^2 - r_{bp}^2} + \sqrt{r_{ag}^2 - r_{bg}^2} \right) - \left( \sqrt{r_p^2 - r_{bp}^2} + \sqrt{r_g^2 - r_{bg}^2} \right)$$

$$r_{bp} = r_p \cos \theta = 37.787 \text{ mm}, r_{bg} = r_g \cos \theta = 73.587 \text{ mm}$$

$$L = \left( \sqrt{\left( \frac{88.892}{2} \right)^2 - 37.787^2} + \sqrt{\left( \frac{165.086}{2} \right)^2 - 73.587^2} \right) - \left( \sqrt{40.213^2 - 37.787^2} + \sqrt{78.310^2 - 73.587^2} \right)$$

$$L = (23.400 + 37.393) - (13.756 + 26.783)$$

$$L = 20.254 \text{ mm}$$

$$cr = \frac{20.254}{12.447} = 1.620 (> 1.0)$$

At new center distance of  $CD_{new}=1.02*CD$

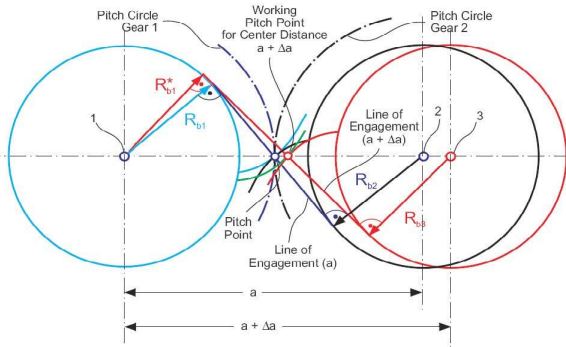

$$\cos \theta_{new} = \frac{r_{bp} + r_{bg}}{CD_{new}} = \frac{37.787 + 73.587}{(118.523) \times 1.02} = 0.92125$$

$$\theta_{new} = 22.89^\circ (> 20^\circ)$$

$$r_{p_{new}} = \frac{r_{bp}}{\cos \theta_n} = \frac{37.787}{\cos 22.89} = 41.016 \text{ mm}, d_p = 82.032 \text{ mm}$$

$$r_{g_{new}} = \frac{r_{bg}}{\cos \theta_n} = \frac{73.587}{\cos 22.89} = 79.877 \text{ mm}, d_g = 159.754 \text{ mm}$$

New contact ratio

$$cr_{new} = \frac{L_{new}}{P_b} : L_{new} = \left[ \sqrt{r_{ap}^2 - r_{bp}^2} + \sqrt{r_{ag}^2 - r_{bg}^2} \right] - \left[ \sqrt{r_{p_{new}}^2 - r_{bp}^2} + \sqrt{r_{g_{new}}^2 - r_{bg}^2} \right]$$

$$L_{new} = 13.772 \text{ mm}$$

$$cr_{new} = \frac{13.772}{12.497} = 1.102 (> 1.0)$$