

# ME 224 MECH. OF MAT.

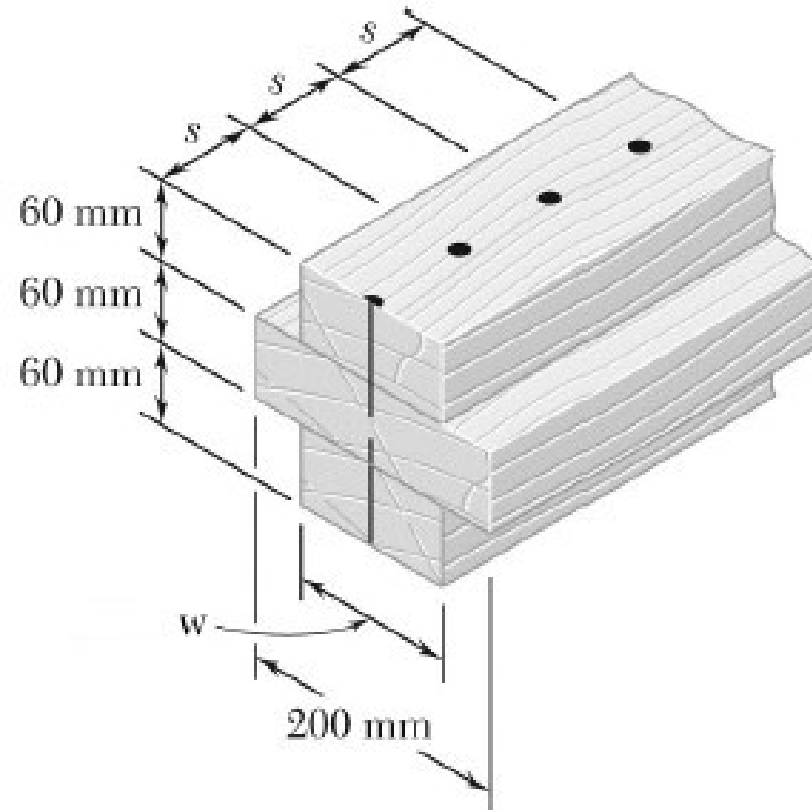

## PROBLEM HOUR VI

Q1) Three boards are nailed together to form a beam shown, which is subjected to a vertical shear. Knowing that the spacing between the nails is  $s = 75\text{ mm}$  and that the allowable shearing force in each nail is  $400\text{ N}$ , determine the allowable shear when  $w = 120\text{ mm}$ .



Q2) For the beam and loading shown, consider section n-n and determine (a) the largest shearing stress in that section, (b) the shearing stress at point a.

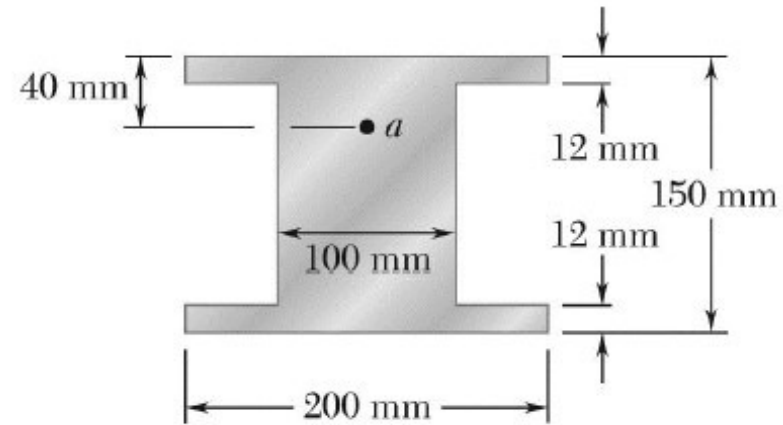
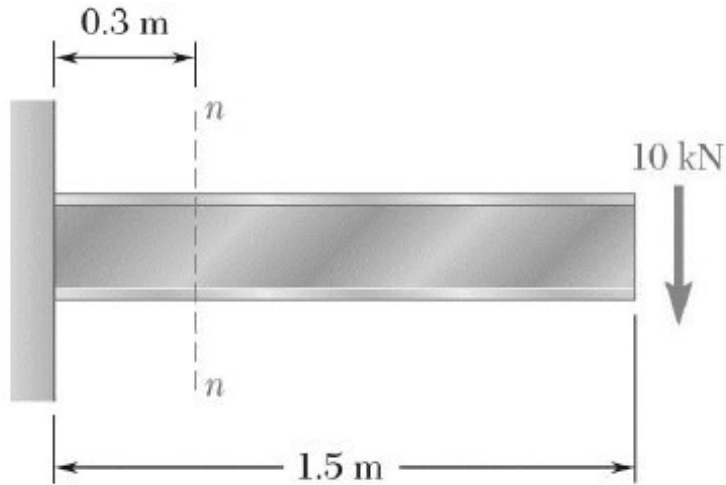

Q3) For the beam and loading shown, consider section  $n-n$  and determine (a) the largest shearing stress in that section, (b) the shearing stress at point  $a$ .

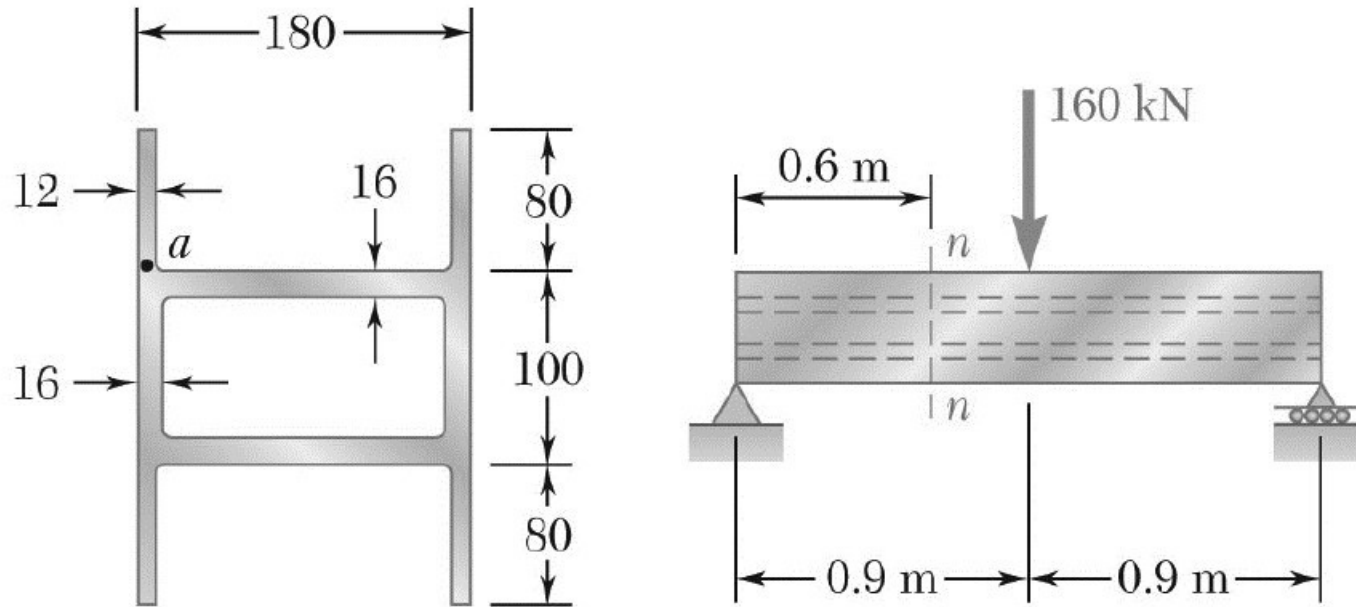

Q4) For a beam having the cross section shown, determine the largest allowable vertical shear if the shearing stress is not to exceed 60 MPa.

