

EXPERIMENT 4

NETWORK THEOREMS THEVENIN, NORTON AND SUPERPOSITION

OBJECTIVE

The purpose of this experiment is to verify experimentally the important network theorems such as Thevenin's, Norton's and Superposition

EQUIPMENT NEEDED

- Digital Multimeter (DMM)
- Avometer (AVO8)
- Power Supply
- Resistors

PRELIMINARY WORK

P1 Calculate the Thevenin and Norton Equivalents for the circuit to the left of R_L in Figure 4.1.

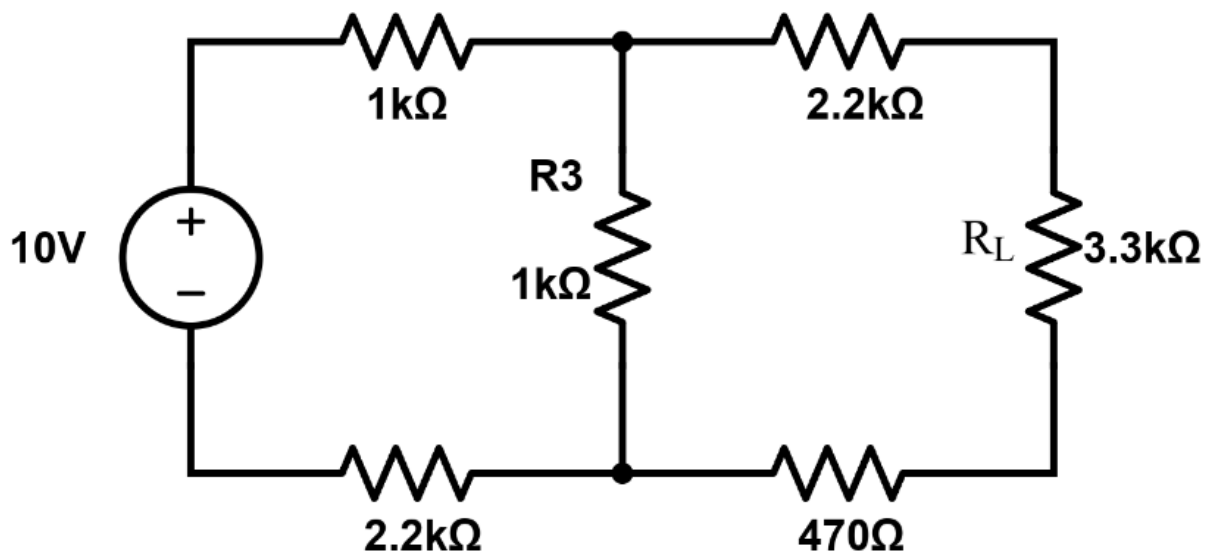

Figure 4.1

P2 Superposition Theorem

a) For the circuit in Figure 4.2, calculate V_1 and V_2 .

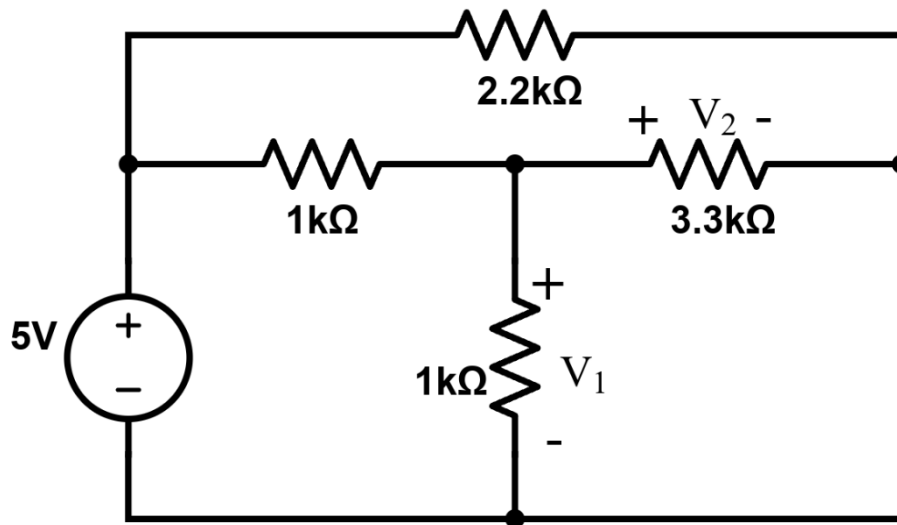

Figure 4.2

b) For the circuit in Figure 4.3, calculate V_1 and V_2 .

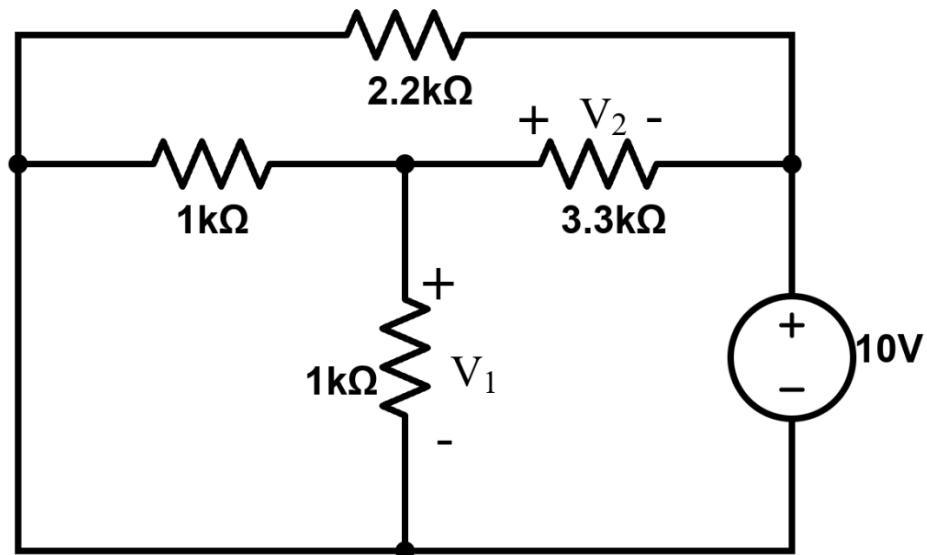

Figure 4.3

c) For the circuit in Figure 4.4, calculate V_1 and V_2 .

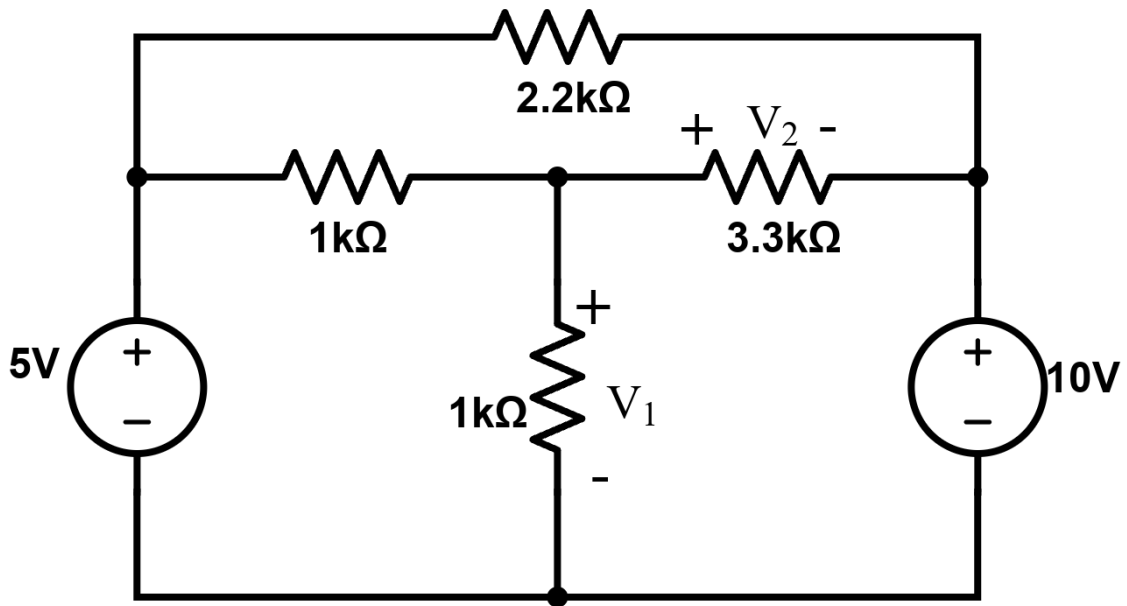

Figure 4.4

	V_1	V_2
10V Circuit		
5V Circuit		
Total		

EXPERIMENTAL WORK

E1 Thevenin & Norton Networks

- a) Construct the circuit of Figure 4.5. Measure the voltage, V_L .

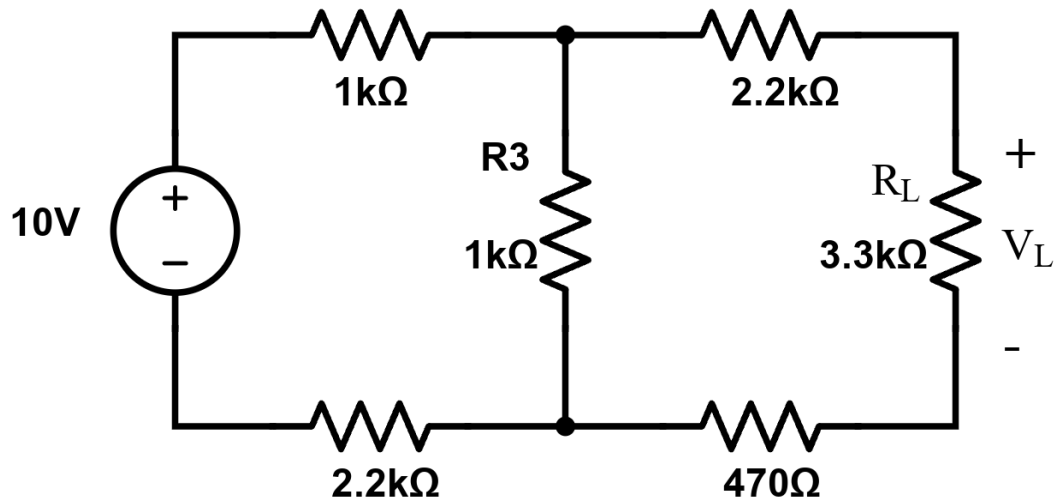

Figure 4.5

- b) Remove the 3.3kΩ resistor and measure and record V_{TH} .

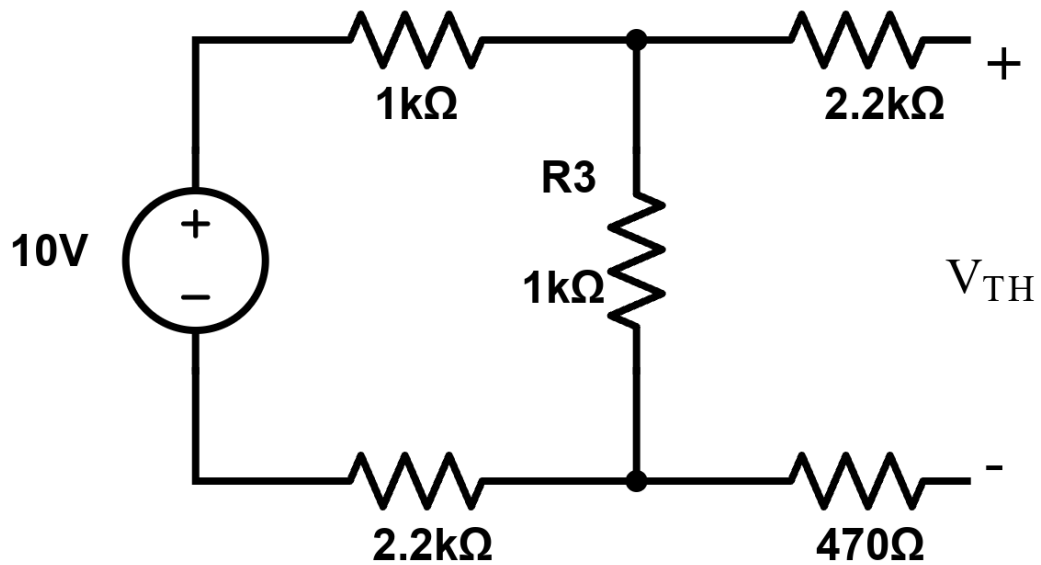

Figure 4.6

- c) Place a short circuit between $2.2\text{k}\Omega$ and 470Ω and measure the current, I_{SC} , flowing through this short circuit.

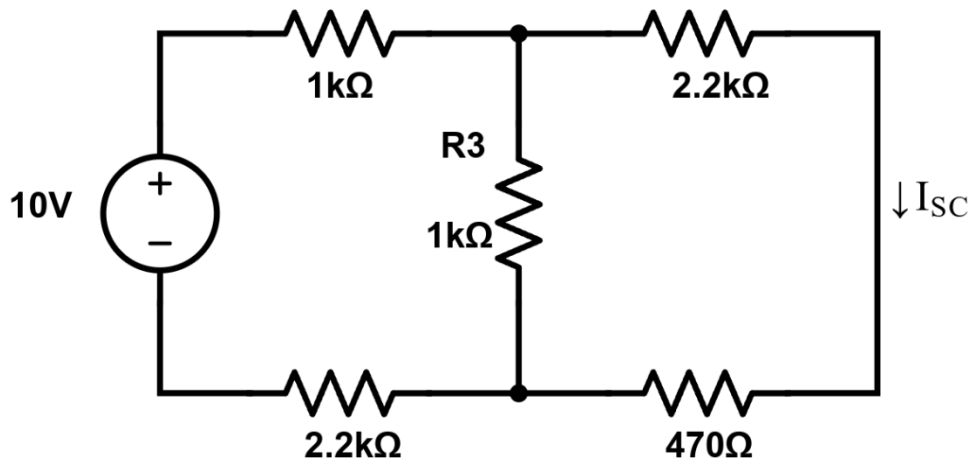

Figure 4.7

- d) Remove the 10 volt source and replace it with a short circuit. Use DMM in resistance measurement mode to measure R_{TH} .

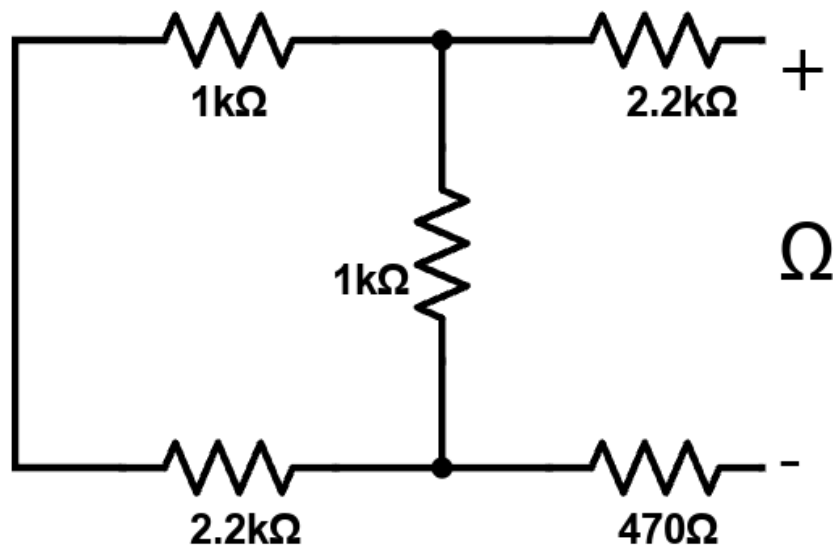

Figure 4.8

- e) Draw Thevenin and Norton Equivalent circuits according to the values you found in part b, c and d.
- f) Using the measured values of V_{TH} and R_{TH} (using closest available standard values in laboratory) construct the Thevenin equivalent of the circuit. Measure the voltage across $3.3k\Omega$. Compare to the value measured in step part a.

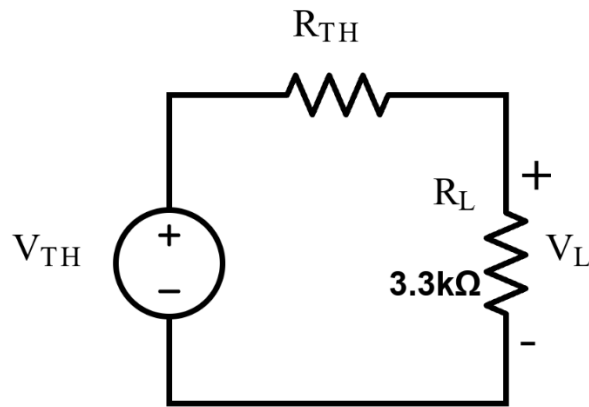

Figure 4.9

E2 Superposition Theorem

- a) Construct the circuit of Figure 4.10 and measure V_1 and V_2 .

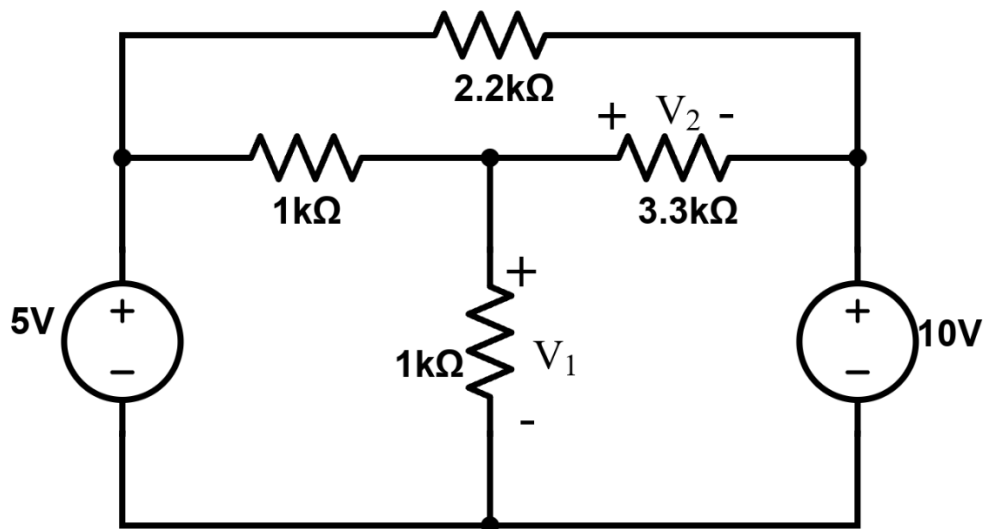

Figure 4.10

- b) Remove the 5 volt source and replace it with a short circuit. Measure measure V_1 and V_2 .

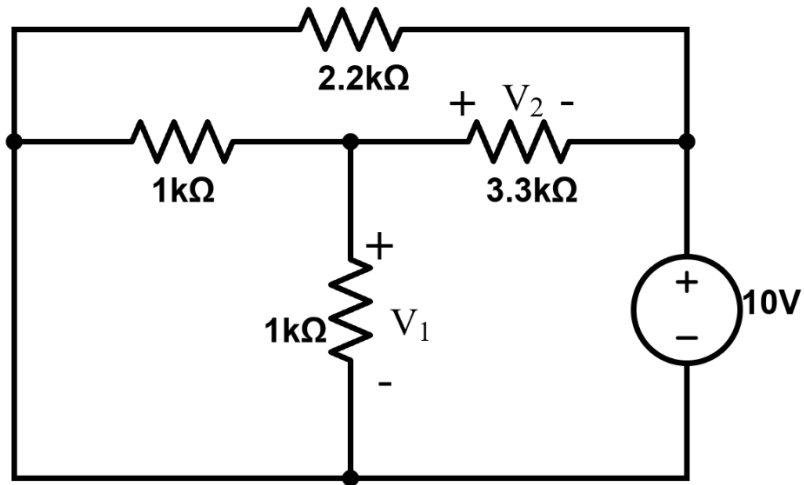

Figure 4.11

- c) Replace the 5 volt source and remove the 10 volt source and replace it with a short circuit. Measure measure V_1 and V_2 again.

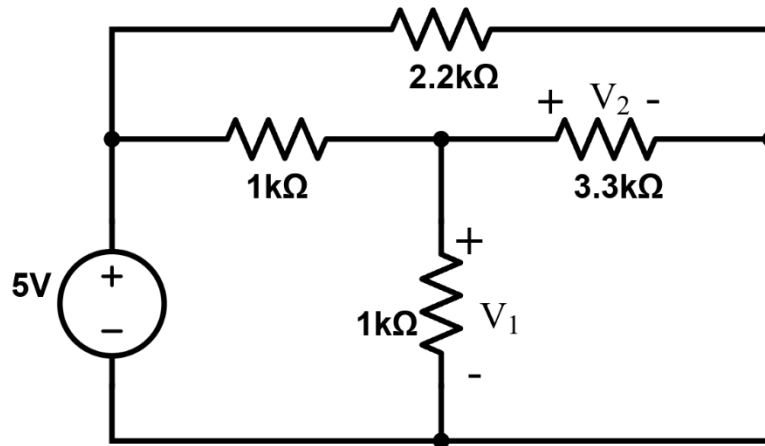

Figure 4.12

- d) Use your results to verify the principle of superposition.

	V_1	V_2
10V Circuit		
5V Circuit		
Total		